

# Feeders & Screeners

Carrier Vibrating Equipment provides effective and economical vibratory feeders to meter bulk materials at a controlled rate. Our wide range of robust feeders have multiple design options and are customized in size and construction materials to suit your specific application needs.

Carrier's vibratory screeners are able to scalp, dewater, or separate materials using a wide variety of screening media. With options such as multiple decks on a single unit, removable dust-tight covers and various screen sizes and designs, our units are custom engineered to improve your process.



## **Typical Applications:**

- Reclaim Hoppers & Bins
- Storage Silos
- Product Sizing
- Crushing Systems



## Feeders Features & Benefits

- Large capacity vibrating feeders handle heavy headloads up to 3,000 tons per hour
- Natural frequency drive units maintain stroke under extreme headloads for reliable operation
- Drive units provide efficient conveying of coarse materials in severe operating environments
- Fixed or variable feed rates provide versatility for different process requirements
- Robust design for long-lasting durability

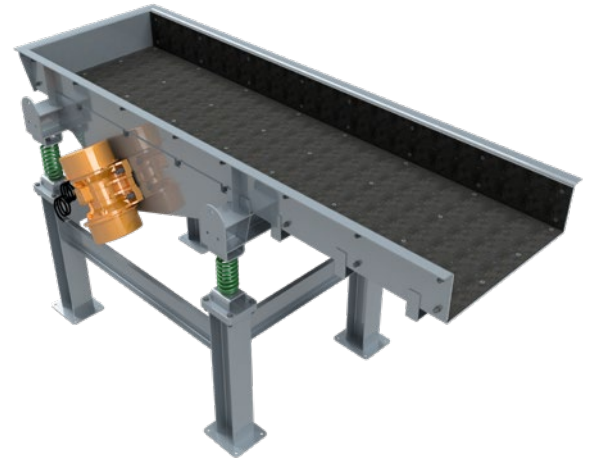

## Options

### Isolation Arrangements

Supported from below or suspended from above, Carrier offers several isolation configurations using steel coil or soft rubber isolation springs to isolate vibration from surrounding structures.



### Grizzly Feeders

Grizzly feeders feature bars made of reinforced or hardened steel that are self-relieved to prevent product from wedging and keep material flowing. Ideal for scalping mining minerals and aggregates such as limestone, bauxite, and coal to reduce crushing loads.

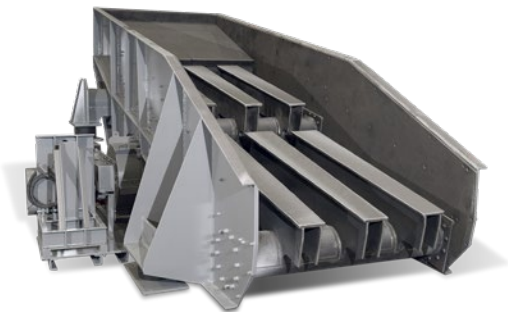

### Bearings

Specially engineered bearings for long-lasting durability.

### Discharge Ports

Available with side, end, intermediate, straight, or bias discharges provide flexibility for various design and process specifications.



### Complete Customization

Removable dust-tight covers, overhead drive, liners, explosion-proof motors, construction with a variety of alloys, and more.



## Screeners Features & Benefits

- Robust designs handle up to 1,500 tons/hr with reliable operation and maximum screening efficiency
- Custom screening deck designs accommodate wet or dry screening
- Vibratory screeners with elliptical or circular motion for increased efficiency
- Optional ball decks to minimize blinding
- Side, end, intermediate, straight, or bias discharges accommodate various process specifications

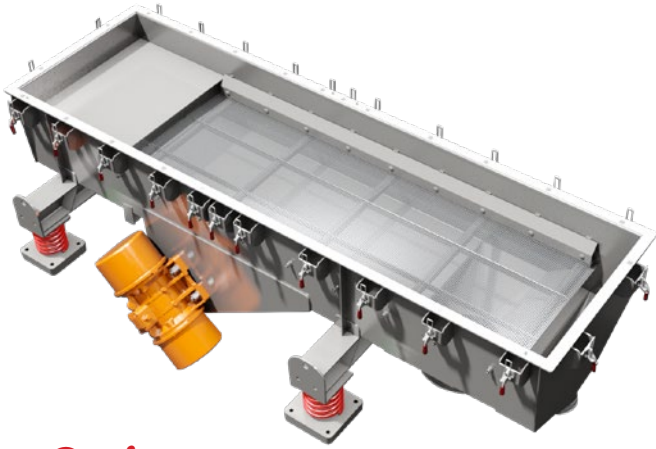

## Options

### Deck Designs

Single, double or triple deck designs and custom units that accommodate multiple decks on a single unit. When screening and separating bulk solid materials by size or density is required, the top screen can separate oversized materials while the bottom screen separates fines from the process flow. Middle screens can process two size grades of material. Perforated plate, wire mesh, and wedge wire deck designs are available for your specific application requirements.

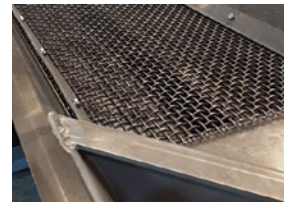
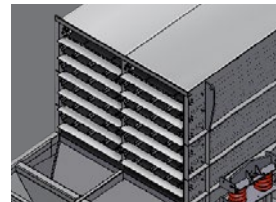
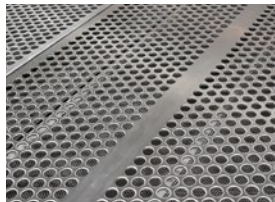

### Grizzly Screeners

Grizzly screeners perform sizing and classifying of a wide variety of materials in a single processing step, reliably and efficiently.

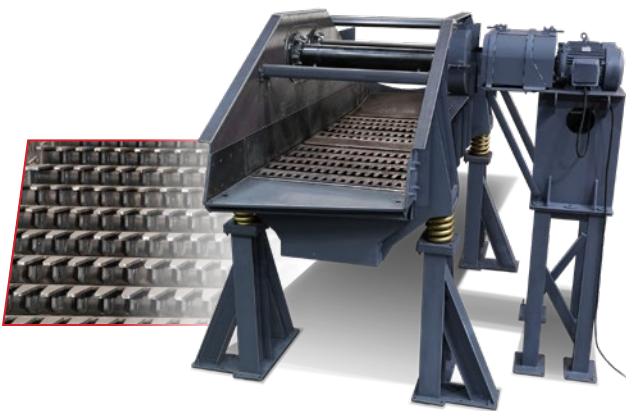

### High Temperature Designs

High temperature vibratory screener designs available for handling and screening high temperature materials with maximum efficiency.



### Cleanability

Units can be specially designed for applications requiring frequent clean out such as those in the food, pet food, and dairy industry.



### Size & Capacity

Available in widths from 6 inches to 10 feet and lengths up to 200 feet with capacities up to 1500 tons per hour.

### Materials of Construction

Reduce product adhesion with polished troughs or material surfaces fabricated in carbon steel or other alloys.

## Drive Systems

Tuned, two-mass, natural frequency and brute-force direct drive systems are available to move a variety of bulk materials.

## Natural Frequency *VS.* Brute Force Drives

### Natural Frequency

Pioneered by Carrier, these units deliver ultimate performance and efficiency. Careful design considerations permit the internal spring system to amplify the drive force to compensate for heavy load demands by increasing stroke length.



### Brute Force Drives

Carrier's reliable brute force direct drives offer versatile performance that is not susceptible to upset conditions caused by product overload. The trough is vibrated directly by eccentric weighted motors. Capacities are typically controlled by adjusting the speed with a VFD.

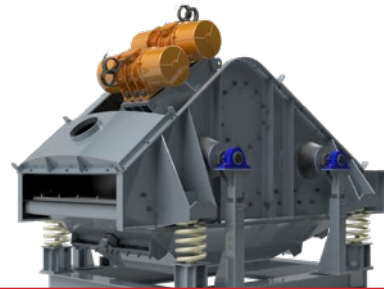

## Special Purpose: Air Knife Separators

Carrier's air knife system provides a highly efficient means of separating heavy metal, stone, rock, brick, plastics, paper and other debris from used beverage container (UBC) scrap, construction and demolition debris (C&D), or other applications with combined high and low density materials. Recyclable materials such as metals, paper, and plastic can be recovered.

- Versatile design separates heavier materials from lighter materials such as aluminum, paper, plastic, and wood
- Vibrating feeder & high-velocity air knife/curtain combination reduces residual contaminant build-up in the recycled alloy as well as furnace melt loss in the aluminum industry
- Adjustable nozzle assembly provides fine-tuning in the field for precision operation

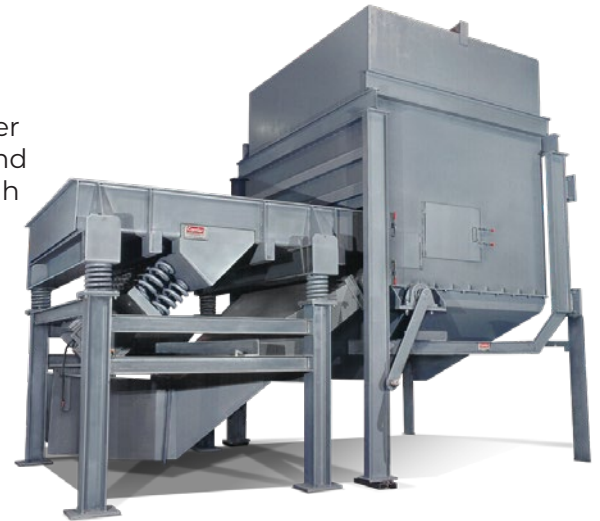

## Comprehensive Line of Feeders & Screeners

Whatever the industry or application, when you need to feed, convey, sort, or screen, Carrier feeders and screeners are proven to meet today's unique processing challenges.



## Industries & Applications

- Biomass, Paper & Wood
- Catalysts, Chemical Compounds, Powders & Resins
- Clay, Brick & Concrete Mix
- Coal & Other Minerals & Ores
- Fertilizer
- Fiberglass
- Food, Pet Foods & Dairy
- Foundry Castings, Sand, Sprue & Scrap
- Frac Sand, Sand & Aggregates
- Glass Cullet
- Pelletized Plastics
- Pharmaceuticals
- Recycling & Waste Materials
- Refuse, Recycled Glass
- Rubber
- Used Beverage Cans (UBC)
- And much more



Recycling/Waste Materials  
Feeder-Screener



Suspended Coal Feeder



Two-Way Feeder

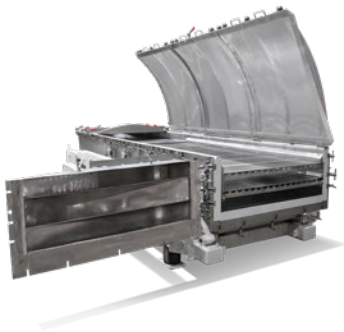

Multiple Deck Screener

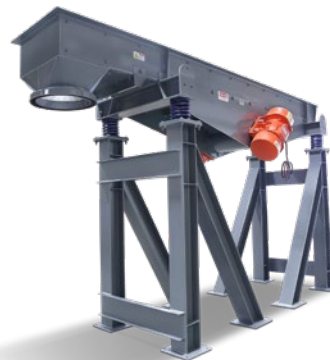

Sand Feeder



Foundry Furnace Feeder

## Complete, Integrated Systems

Carrier designs and manufactures additional processing equipment that can be integrated upstream or downstream for complete multistep process lines.



## Engineering & Manufacturing

- Technology profile of over 150 patents
- Equipment designs are verified using Finite Element Analysis (FEA) to ensure trouble-free service and long life
- 3D equipment modeling
- State-of-the-art manufacturing facilities on 3 continents with robotic cutting and welding
- Manufacturing expertise working with mild steel, various grades of stainless steel, duplex steels and other exotic alloys for specialty applications
- Welders certified to ASME & AWS standards
- ISO 9001:2015 certified

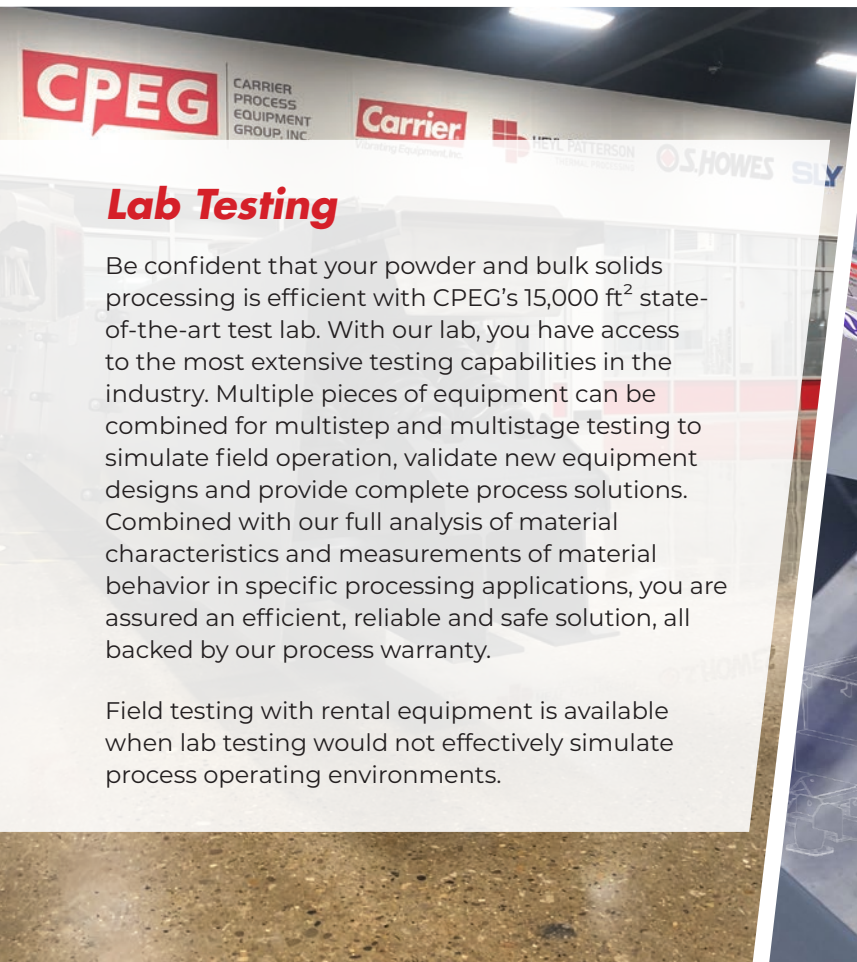

### Lab Testing

Be confident that your powder and bulk solids processing is efficient with CPEG's 15,000 ft<sup>2</sup> state-of-the-art test lab. With our lab, you have access to the most extensive testing capabilities in the industry. Multiple pieces of equipment can be combined for multistep and multistage testing to simulate field operation, validate new equipment designs and provide complete process solutions. Combined with our full analysis of material characteristics and measurements of material behavior in specific processing applications, you are assured an efficient, reliable and safe solution, all backed by our process warranty.

Field testing with rental equipment is available when lab testing would not effectively simulate process operating environments.

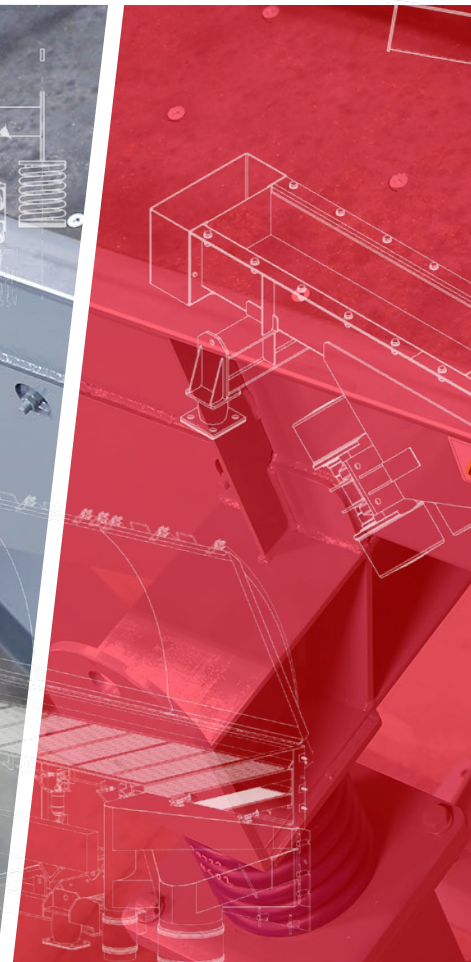

#### AMERICAS

Carrier Vibrating Equipment, Inc.  
3400 Fern Valley Rd  
Louisville, KY 40213, United States  
Tel: +1-502-969-3171 | Fax: +1-502-969-3172  
carriervibrating.com | cve@carriervibrating.com

#### EUROPE

Carrier Europe SA  
Rue Joseph Luns 52  
B-1401 Nivelles, Belgium  
Tel: +32 67 40 01 40  
carriereurope.be | ceur@carriereurope.be

#### CHINA

Carrier Vibrating Equipment (Shanghai) Co., Ltd.  
#1 Bldg., #88 Shenzhou Road, Fengcheng Town  
Fengxian District | Shanghai, 201411 China  
Tel: +86 21-33925800  
cves@carriervibrating.com.cn

